



GROUND
SOURCE
HEAT PUMPS

2 - 6,5 KW

5 DECADES USE EXPERIENCE



2 / 3

M-TEC HEAT PUMPS

M-TEC, based in Austria, is a "green tech" company with a special focus on the development and production of highly efficient heat pumps.

As a specialist in intelligent control technology and for a sustainable Energy management, we develop cross-system solutions for heating, cooling, ventilation, water heating, photovoltaics and solar thermal energy.

More than five decades of experience with over 20.000 heat pumps, patents in the field of innovative complete heat pump systems and the constant further development of heat pump technology are important cornerstones of the corporate strategy.



DR. HANNES JAKOB, MBA
CEO -EXECUTIVE PARTNER

"M-TEC stands for honesty, trust and the highest quality for more than 5 decades. As managing director, I see it as my task not only to support you in your heat pump project, but also to inspire you with our cooperation."



100 % SUSTAINABLE:

M-TEC International heat pumps are produced in Upper Austria with 100% renewable energy - 100% energy generated from our own photovoltaic system and our own hydropower plant.

Our mission is people's independence in the energy supply of their homes through Heat pump, photovoltaic, storage and E-mobility, controlled by our innovative Energy management system E-Smart.



HOW AN M-TEC HEAT PUMP WORKS

In principle, the heat pump works like a refrigerator: the same technique, only reversed utility. The heat pump receives energy from the heat source side (earth, water or air) at a low temperature and releases heat with a higher temperature on the heating side.

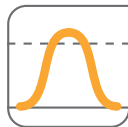

INTELLIGENT POWER CONTROL

The M-TEC International Power Inverter is a true innovation in the field of heat pump technology. The principle is very simple: The inverter adjusts the energy used to the actual needs of your home. The efficiency is thereby improved by approximately 20% and the life span of the compressor is prolonged due to significantly less switch-on cycles.

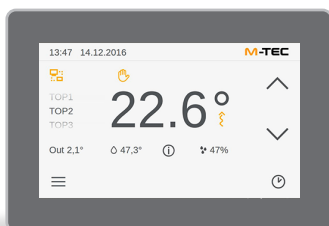

NATURAL HEAT SOURCES FOR THE ENERGY GENERATION

This heat pump uses solar energy that is stored in the ground. This solar energy is available at all times. Whether day or night, summer or winter, even infinite, because it is constantly renewed. Due to its relatively constant ground temperature, the earth is a particularly good heat store. From a depth of 1.3 m, there are hardly any temperature fluctuations, no matter how cold it is outside. We use either a flat collector for our system (an extensive pipe system that is laid about 1.3 m below the surface of the earth, a geothermal probe that is inserted via a deep borehole (50-150 m), or geothermal baskets that are particularly suitable where space is limited. The combination with PVT is also new. Collectors Photovoltaic thermal collectors (PVT) combine PV modules and solar thermal collectors in one housing. The former convert solar radiation into electricity, while the latter uses the waste heat produced as a heat source for the heat pump.



Brine heat pump with 2 to 6.5 kW heat output and highest efficiency



Surface collectors, deep drilling, Ice storage, solar system, air evaporator and PVT collectors - **the new source management makes it possible to integrate multiple sources.**

THE SMALLEST MODULATING BRINE HEAT PUMP INCLUDED SOURCE MIXER FOR PVT SYSTEMS

From now on, next to the heat pump, there is **only 0.25 m³** and the E-Smart energy management system circulating pumps, a diverter valve for hot water, Expansion tanks, an electric heater and a source mixer for PVT systems. This unique heat pump can cool both passively and actively.

A true powerhouse that even in the smallest niches or there is still enough space under the stairs.

M-TEC Technology

HEATING

COOLING

CONNECT ALL THE DEVICES IN YOUR HOME EASILY AND EFFICIENTLY

Thanks to "Internet Inside", M-TEC heat pumps have been able to take advantage of current developments for years. The advantages of digital networking are obvious. Maintenance and fault diagnosis can be carried out quickly and easily via remote maintenance. Travel costs and time are eliminated. In addition, you can control your heating from anywhere: Whether smartphone or tablet - use the various options to manage your room temperatures.

6 / 7



SMART GRID

M-TEC International heat pumps are already "Smart Grid Ready" today.

With this function, you can use the cost savings of future electricity networks. In times where generally less power is consumed, electricity is also cheaper. Therefore the operating time of the heat pump should be shifted to this period. This is fully automated by M-TEC International's intelligent control system.



INTERNET INSIDE

All M-TEC heat pumps are already equipped with the future technology of "Internet Inside". This allows you as a customer to control your heat pump from your mobile phone, tablet or PC. If the heat pump is no longer working optimally, the heat pump automatically signals the problem to your selected heat pump installer. Via "Internet Inside", these adjustments can be made to the control settings, without having to be on site. This saves your time and money.



INTEGRATION OF EXTERNAL SYSTEMS

The integration of a photovoltaic system, solar system or house management system are possible thanks to the intelligent control of the M-TEC heat pump.

Photovoltaic integration can use the self-generated electricity for space heating as well as hot water preparation, preferably for own consumption. Feeding your own PV electricity to the grid will only occur when the hot water storage tank is charged and the house is comfortably warm.

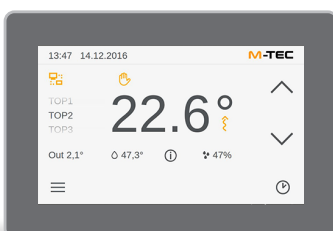

Whether touch operation, M-TEC control or control via smartphone - networked Technology makes your heat pump versatile to use.



TOP SYSTEM CONCEPT

The best heat pump is only as good as the designed system concept. M-TEC International is always optimally oriented to this development!

This results in heating systems with maximum efficiency, which is permanently tested and confirmed by independent authorized testing institutes such as the Austrian Institute of Technology in Austria.



display model Premium

ADVANTAGES

- Maximum efficiency of heat pump systems
- High innovative power also in the field of control technology
 - Inverter technology
 - Latest overheating control
 - PV Self-consumption optimization
 - Advanced "Smart Grid" functionality
 - External systems can be integrated
 - LAN interface in each heat pump
 - Easy to use touch screen technology, tablets or smartphones
- Energy-Managementsystem **E-SMART*** for best integration of photovoltaics, Battery storage, e-mobility, ...



* optionally included in the E-Smart Premium package



NEW INJECTION TECHNOLOGY

Due to the constantly changing parameters of an inverter heat pump, special attention must be paid to the overheating control. The absolutely new, model-based control is a product of years of experience. Proactive reactances are made to future speed changes and therefore the efficiency of the heat pump is maximized.



SOURCES OF ENERGY FOR THE M-TEC HEAT PUMPS

Whether earth, air or ground water – with the solutions from M-TEC you can use natural resources in an efficient and sustainable way. Our ground source heat pumps are ready to use for usual heat sources.

AIR SOURCE

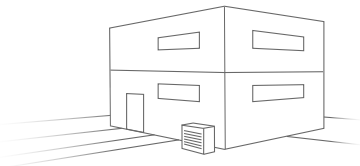

Air source heat pumps draw the energy to heat your home from the ambient air. These are mainly used when geothermal heat pumps are not possible or make economic sense.

The efficiency of an air heat pump depends largely on the ambient temperature (the higher the better).

DEEP DRILLING GEOTHERMAL PROBE

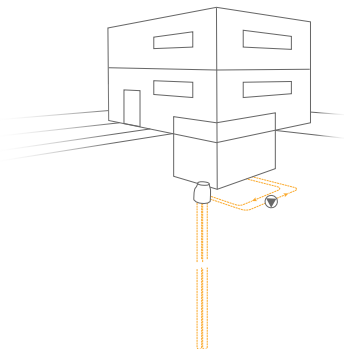

In the case of geothermal probes, a frost-proof liquid, the brine, circulates through a plastic tube in a closed circuit.

A geothermal probe requires only a small area of land from your garden. Since, from a depth of 10 meters, the temperature of the soil is almost constant all year round, and is therefore independent of seasonal fluctuations, the geothermal probe is very effective especially in winter at low temperatures. In summer it is ideal for cooling. The necessary length of the probe and thus the depth of the bore depends on the heat demand of the building and the thermal conductivity of the soil.

With an average single-family new building it is about 120 meters.

GROUND COLLECTOR BRINE

The ground of your property is a free and inexhaustible source of energy. Thanks to sun, rain and geothermal energy, your garden is always recharged like an energy storage, and is available year-round free of charge. Flat collectors operate with a horizontal pipe system in the ground, which is laid in a similar way as an UFH system in a snake-shape at a depth of approx. 1.3 m.

The required collector area depends on the heat demand of the building and the thermal conductivity of the soil. For an average single-family new building, it is about one and a half times the heated living space.

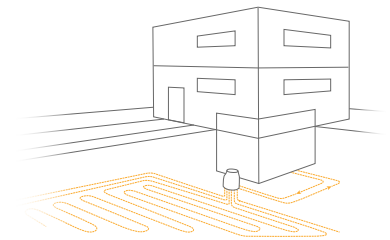

GROUNDWATER

If groundwater is available in a suitable depth and in sufficient quantity, you have an excellent heat source for a heat pump.

The temperature is constant between 7 and 12 °C. Due to the constant temperature of the ground water you can reach the highest levels of efficiency even at the lowest outside temperatures. The two wells require only little space and are therefore ideal for small grounds. With this system, not only heating is possible - you can also use the heat pump for cooling and therefore create a comfortable room climate in the summer. Cooling takes place via the "heating system". The heat extracted from the room is transferred to the ground water via the heat pump.

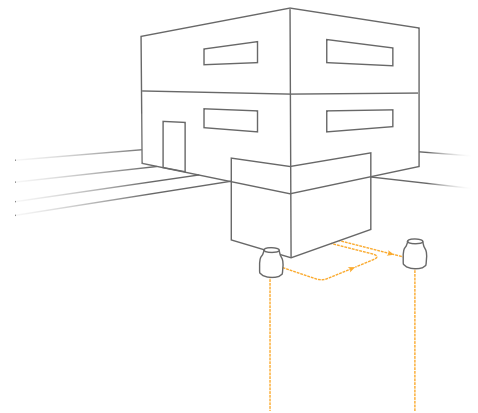

PHOTOVOLTAIC-THERMAL COLLECTORS (PVT)

Photovoltaic-thermal collectors (PVT) are PV-modules and solarthermal collectors combined in one housing.

One collector parts converts the sun exposure into electricity, during the other part is using the created heat as a heat source for the heat pump.

This heat source is mostly combined with other heat sources like ground- or air source.

A new source management system was developed for these systems, which always selects the best/warmest heat source and thus optimizes the annual efficiency of the system.

ADVANTAGES

- Increase the lifetime
- Maintenance by certified specialists
- Flat rate per year

10 ||

INDIVIDUAL WARRANTY EXTENSIONS

Benefit from a specialist in geothermal energy with modern heat pump technology. M-TEC International heat pumps are the product of over 40 years experience in heat pumps and a cooperation in the field of control technology with the global company KEBA. Due to the high quality requirements, it is easy for us to offer extended warranties in addition to the guarantees.

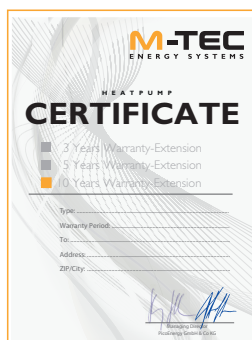

It can be chosen between

**3 years, 5 years or
10 years Warranty-Extension**

on all materials.*

* Prices according to valid M-TEC International price list and valid warranty conditions

Technical Specification		Brine	Water
	Modell	WPS26-V2	WPS-W26-V2
Power range [kW]		2-6 kW	3-8 kW
Energy class VL35 °C		A+++	
Energy class VL55 °C		A++	
Dimensions Heat pump H x W x D [mm]		710 x 600 x 565	
Weight [kg]		79	72
Refrigerant		R410A	
Sound power level acc. EN12102 [dB(A)]		40,8	
Fuse Main Current [A]		1 x C16	
Fuse Controller [A]		1 x C13	
Hydraulic Connection [inch]		3/4"	
Max. Flow temperature [°C]		up to 60	

PERFORMANCE DATA ACCORDING EN 14825

Climate: warmer (ambient temperature = 7 °C)	SCOP 35 °C	5,12	6,69
	η_s 35 °C [%]	199	257
	SCOP 55 °C	3,12	4,31
	η_s 55 °C [%]	136	178
Climate: average (ambient temperature = 2 °C)	SCOP 35 °C	5,13	7,4
	η_s 35 °C [%]	200	290
	SCOP 55 °C	3,73	5,13
	η_s 55 °C [%]	134	198
Climate: colder (ambient temperature = -7 °C)	SCOP 35 °C	5,6	6,61
	η_s 35 °C [%]	207	291
	SCOP 55 °C	3,52	4,66
	η_s 55 °C [%]	140	198

PERFORMANCE DATA ACC. EN 14511

Heating output [kW]	B0/W35 at 72 % Heating output	4,37	W10/W35 at 72 % Heating output	5,91
Power consumption [kW]		0,96		0,98
Coeff. of perf. [COP]		4,57		6,01
Heating output [kW]	Maximum power B0/W35 - 5K at 100 % Heating output	6,45	Maximum power W10/W35 - 5K at 100 % Heating output	8,6
Power consumption [kW]		1,49		1,61
Coeff. of perf. [COP]		4,34		5,36
Heating output [kW]	B0/W30 at 54 % Heating output	3,46	W10/W35 at 54 % Heating output	4,7
Power consumption [kW]		0,64		0,64
Coeff. of perf. [COP]		5,38		7,4
Heating output [kW]	Maximum power B0/W55 - 8K bei 100 % Heizleistung	5,78	Maximum power W10/W55 - 8K at 100 % Heating output	7,72
Power consumption [kW]		2,11		2,38
Coeff. of perf. [COP]		2,74		3,24
Heating output [kW]	Minimum power B0/W55	2,0	Minimalleistung W10/W55	2,7

Compressor-related power deviations of up to 10% are possible.
All Rights Reserved. Technical data is subject to change without notice.

THE E-SMART GENERATION



More and more companies are recognizing the opportunities of an independent energy cycle. This smart Combination opens up considerable savings potential

- Own power supply
- sustainable production of heat and cooling
- Kcost reduction through electromobility

With M-TEC Energy Systems you use a complete system for the production and management of energy.

12

Distribution Partner

M-TEC UK
Unit 6 Mambury Moor Estate,
Bideford,
Devon,
UK.

www.mtec-systems.co.uk

01237 751044
support@mtec-systems.co.uk

Please request our current brochures without obligation

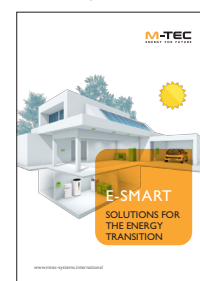

Brochure E-SMART SOLUTIONS FOR THE ENERGY TRANSITION



Brochure AIR SOURCE HEAT PUMPS 2-17 KW



Brochure GROUND SOURCE HEAT PUMPS 3-52 KW



Brochure AIR SOURCE HEAT PUMPS 2-31 KW